

EN 1.2023

Parasol Easy Up

Instructions manual

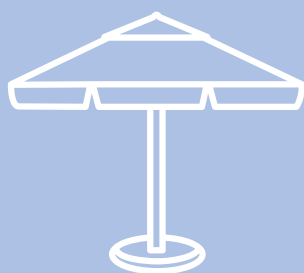

LITEX
PROMO



Table of contents

1. Introduction	2
2. Information	3
2.1. Important symbols	3
2.2. Safety information	4
3. Content	5
3.1. Necessary tools	5
4. Construction	6
5. Space requirements	6
6. Mounting of the parasol + Protective covers	7
6.1. PD450M: 2 x 2 m	7
6.2. PD600RS: 2,5 x 2,5 m, 3 x 3 m, 3 m / 8, 3,5 m / 8	8
6.3. PD700MR: 4 m / 8	9
7. Exploitation of the parasol	10
7.1. Opening the parasol	10
7.2. Closing the parasol	10
8. Maintenance and care	11
9. Storage	12
10. Service and parts	12
11. Support	12
12. Diagram of dismantling the parasol	13

1. Introduction

Litex Promo offers a durable, high-quality advanced product in the form of a sunshade. The characteristic feature of the parasol is its functionality and modern design, providing a sense of comfort. The parasol is a perfect addition to any outdoor area of a restaurant or hotel.

The user manual applies to the sunshade and considers the following:

- Safety,
- Installation,
- Exploitation,
- Maintenance.

The manufacturer Litex Promo Sp. z o.o. is not liable for damage resulting from failure to observe these instructions; such damage is also not subject to warranty. Litex Promo Sp. z o.o. informs you that it is absolutely necessary to read and follow this instruction manual before using the parasol.

You've got doubts? Not everything is understandable?

Contact us:

e-mail: info@litex.pl

The parasol has been designed to act as a shield from the sun and is therefore intended exclusively for such use.

It is absolutely necessary to use it only:

- As intended, i.e. as a sunshade,
- Under correct technical conditions,
- Under correct weather conditions.

Irregularities which may affect the safety and functioning of the sunshade must be rectified immediately, otherwise its further use is prohibited.

All basic maintenance operations described in the manual can be carried out by the user. Any other complicated repair operations should not be carried out by persons not competent to safely operate the tools used for repair.

In connection with our positive verification of the quality and environmental management systems, we present confirmation of our competence in the various fields directly related to the production of high-quality advertising parasols.

Certificates and standards

- ISO 9001:2015 certification
- ISO 14001:2015 certification
- ISO 45001:2018 certification
- AQAP 2110:2016 certification
- ECOVADIS 2023 Certified
- Certificate of Conformity OBAC/0212/CZ/18



We comply with the standards and system environmental management.



We comply with the international standards of the organisation's quality management system.

2. Information

2.1. Important symbols

The graphic symbols in the operating instructions specify the following safety information:

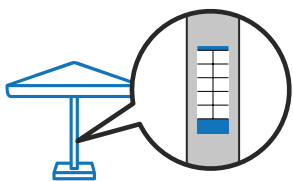

Labeling for parasol – nameplate.



Attention

This symbol indicates information that relates to the danger of injury or accident. The parasol should be transported and installed by at least two people.



Disclaimer

This symbol indicates general instructions for use of the product. In high winds (example 7.9 m/s (28 km/h) - this depends on the model of parasol) the parasol should be folded and protected against damage. Staying under the parasol in winds above the indicated permissible speed can be hazardous to your health or life.



This symbol indicates general operating instructions for the product. The base of the parasol must be levelled.

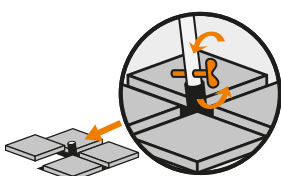

This symbol indicates general operating instructions for the product. The parasol base must be placed on a firm surface. The parasol must be mounted to the cap of the parasol base with the dedicated screw.



This symbol indicates general instructions for use of the product. The parasol base must be dedicated to the type of parasol as declared by the manufacturer (example > 160 kg means that the base must weigh more than 160 kg - it depends on the parasol model).

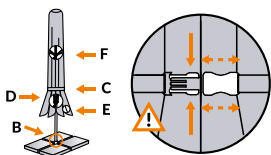

This symbol indicates general instructions for use of the product. When folded, the parasol must be fastened with a safety band to prevent it from opening by itself.



Tip

You've got doubts? Not everything is understandable?
Contact us:
e-mail: info@litex.pl



2.2. Safety information

Attention: Safety hazard

- Place the parasol only on a stable surface and in the original bases designed for it.
- Always ensure that the mast is firmly attached to the base of the parasol.
- Always close the sunshade and put the cover on when moderate winds increase or rain or snow comes.
- Do not hang any objects (e.g. clothes) on the arms of the parasol.
- The parasol is not suitable for use under snow load. In this case the parasol must absolutely be closed and fastened with a band to prevent it from opening by itself.

Description of moderate wind strength:

Winds of approximately 7.9 m/s (28 km/h):

- Effects on land: dust and paper rise, branches start to move.
- Effects on water: small waves on whose crests foam forms, splashing can be heard.

Winds of approximately 10,7 m/s (38 km/h):

- Impacts on land: small branches in motion.
- Effects on water: sea rumbles, wind whistles, longer wave (1,2 m), waves with foam on ridges.

Warning: Risk of accident

- Before opening the sunshade, make sure there are no people around and before closing it, make sure there are no people under the sunshade.
- A sun parasol is not a toy.
- Make sure that children do not use the sunshade as a play area or climbing object.

Caution: Risk of fire

No open fires, e.g. garden barbecues or barbecues, are allowed under or near the parasol.

Note: Risk of damage to health

Repair work on the parasol must only be carried out by a person competent to use the required tools.

Warning: Risk of an accident!

It is easier to install a parasol with the second adult's help. Before installing make sure that core parasol base is safely mounted and stable. Due to the weight of the base, it should be transported by min. two adults. Once the base is in position, insert the parasol into the base cap and secure by inserting and tightening the locking bolt provided. Tighten the bolt to the maximum resistance. During operation, the user must check / control the tightening of the screws of both the base and the parasol cap.

3. Content

PD450M: 2 x 2 m

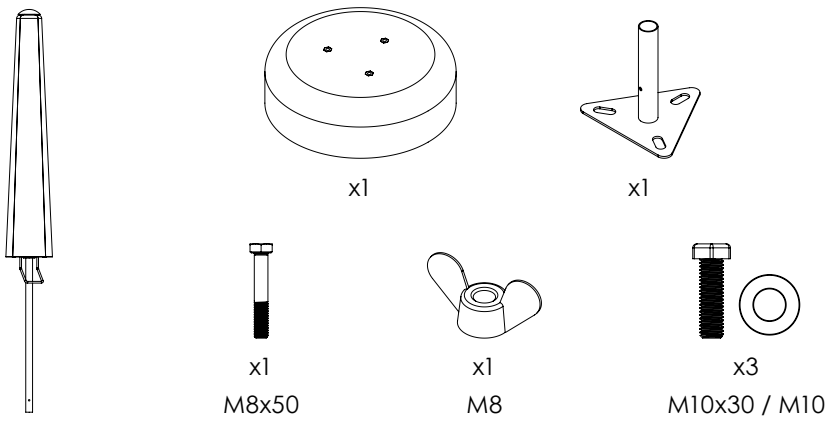

PD600RS: 2,5 x 2,5 m, 3 x 3 m, 3 m / 8, 3,5 m / 8

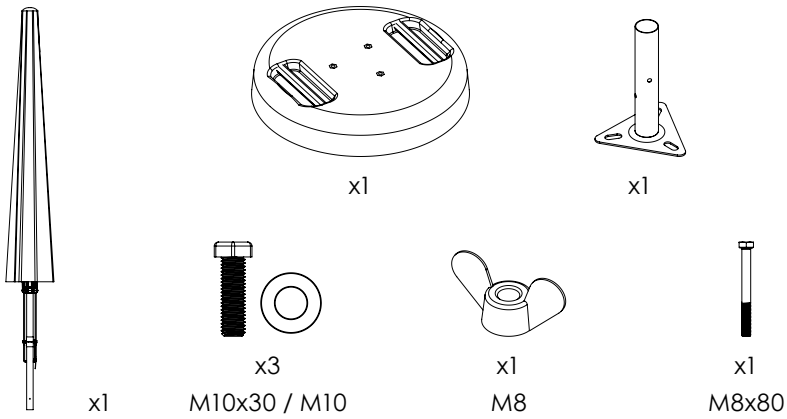

PD700MR: 4 m / 8

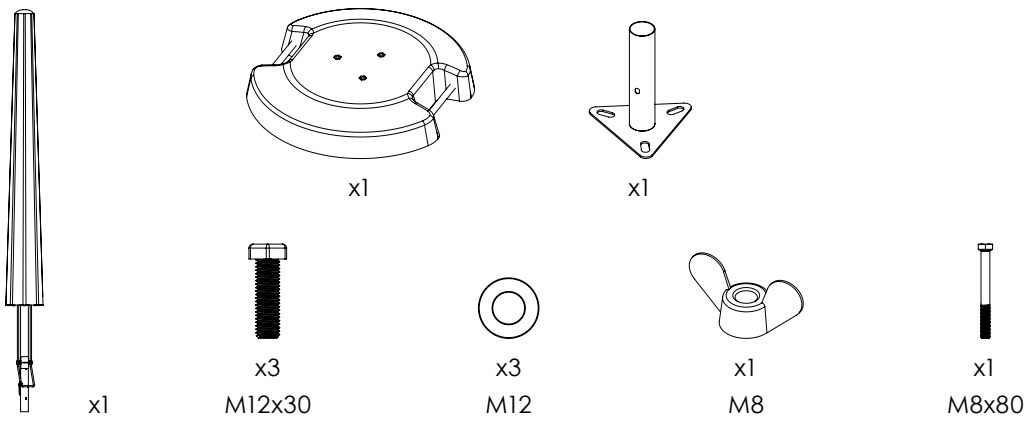

3.1. Necessary tools

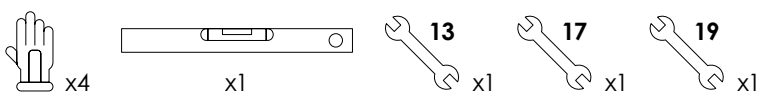

4. Construction

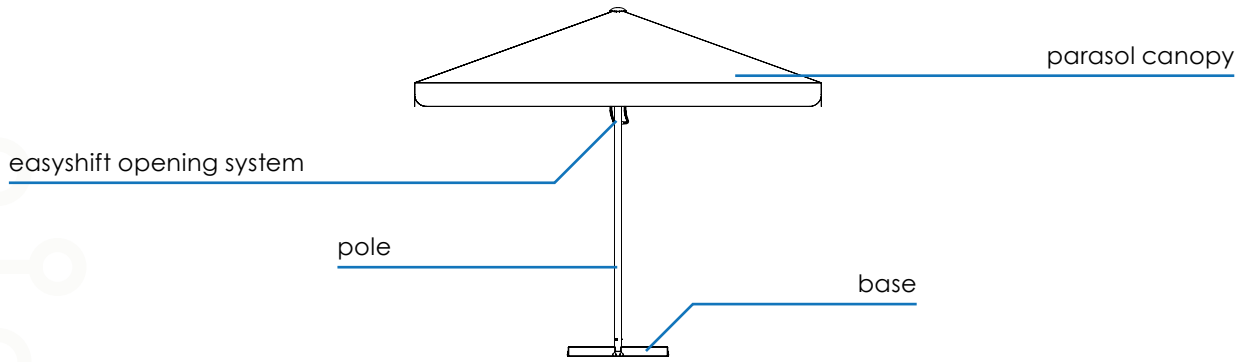

5. Space requirements

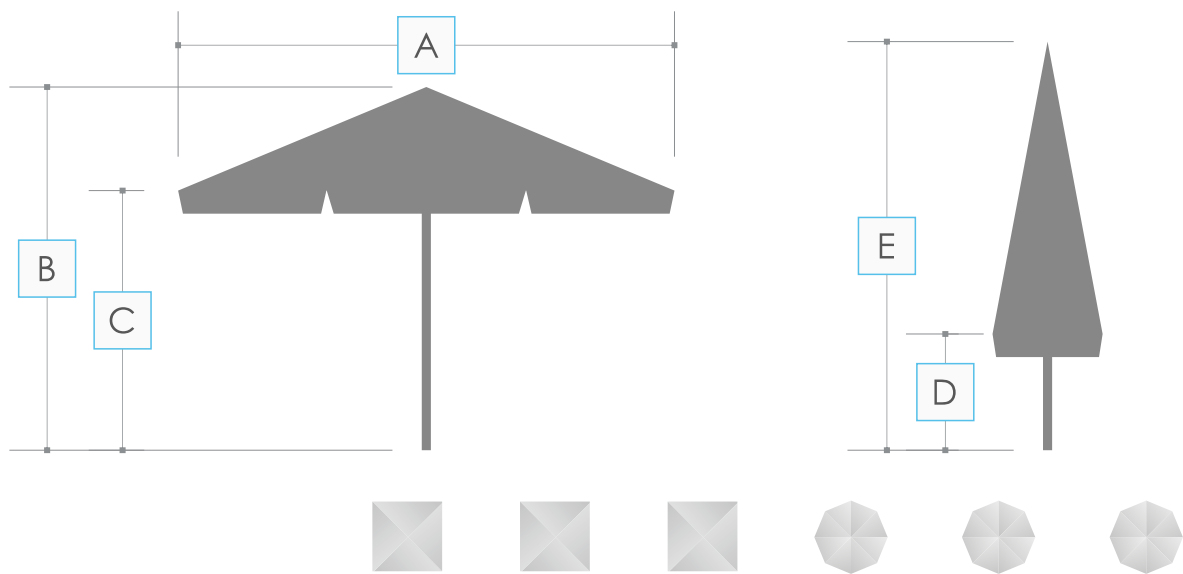

Size	2 x 2 m	2,5 x 2,5 m	3 x 3 m	3 m / 8	3,5 m / 8	4 m / 8
Dimensions [mm]	A: 2000 B: 2350 C: 2000 D: 750 E: 2350	A: 2500 B: 2600 C: 2000 D: 800 E: 2600	A: 3000 B: 2800 C: 2050 D: 600 E: 2800	A: 3000 B: 2600 C: 2150 D: 1000 E: 2600	A: 3500 B: 2600 C: 2020 D: 1000 E: 2600	A: 4000 B: 2800 C: 2110 D: 720 E: 2800



6.1. Mounting of the parasol + Protective cover PD450M: 2 x 2 m

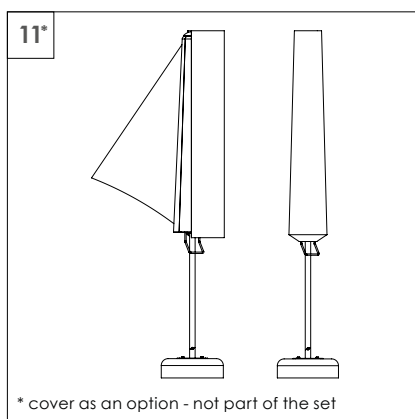
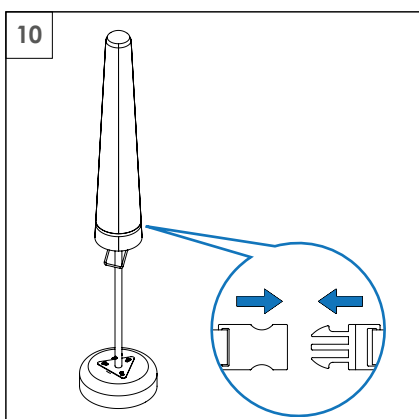
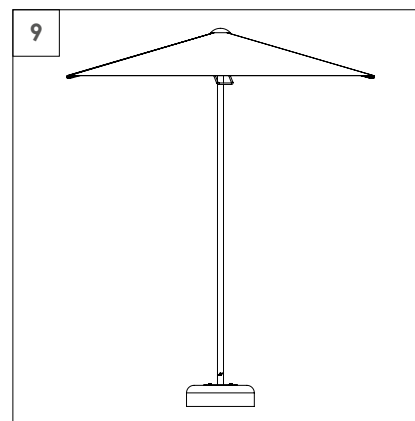
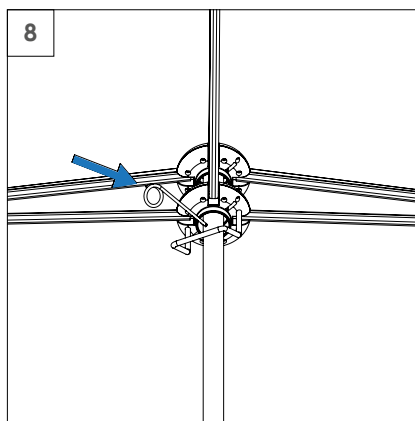
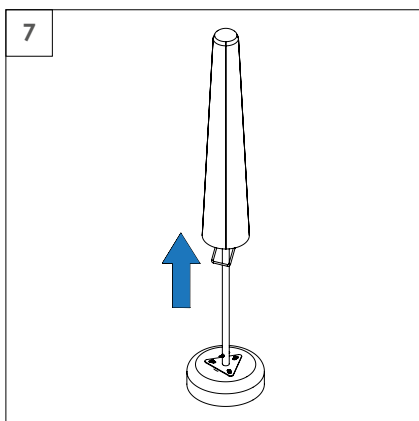
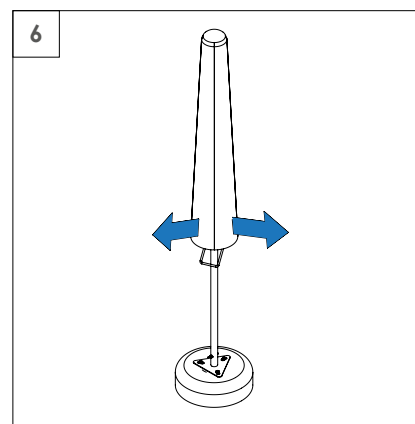
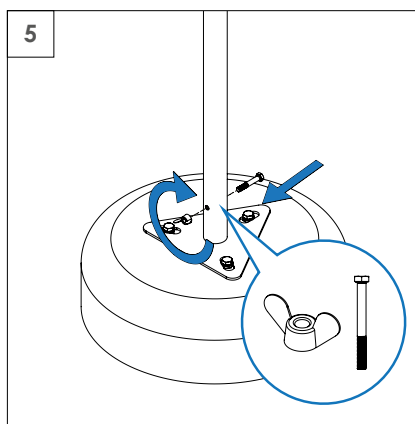
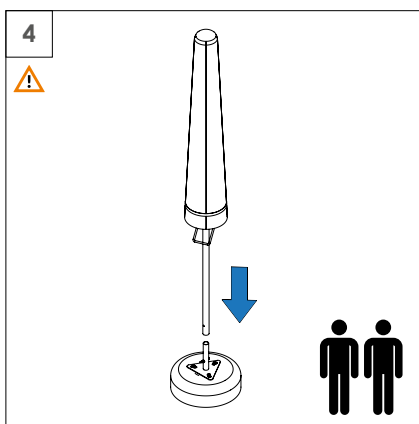
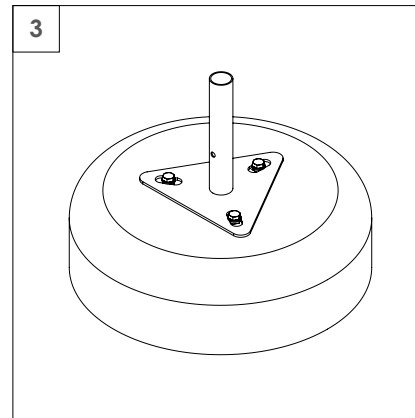
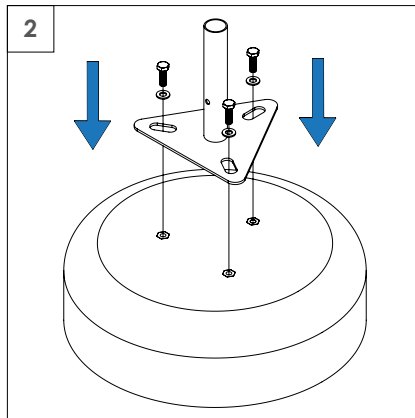
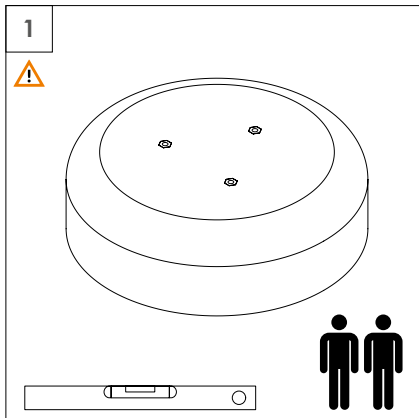

6.2. Mounting of the parasol + Protective cover

PD600RS: 2,5 x 2,5 m, 3 x 3 m, 3 m / 8, 3,5 m / 8

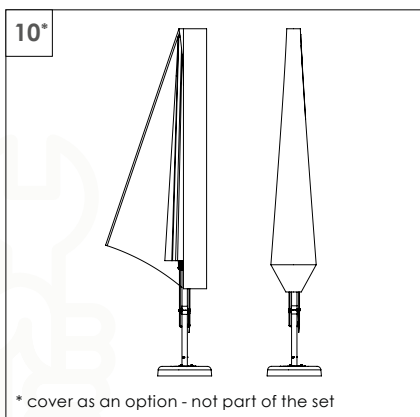
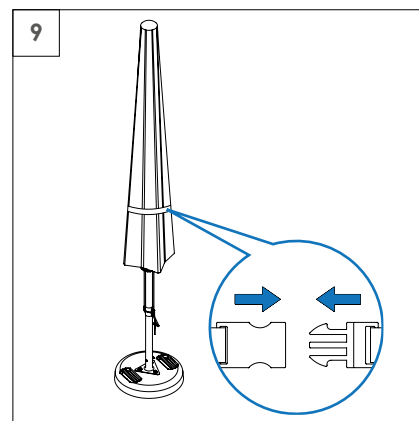
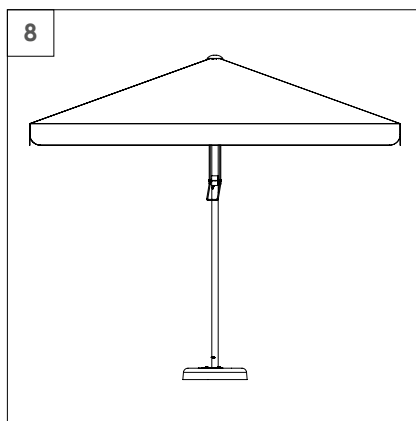
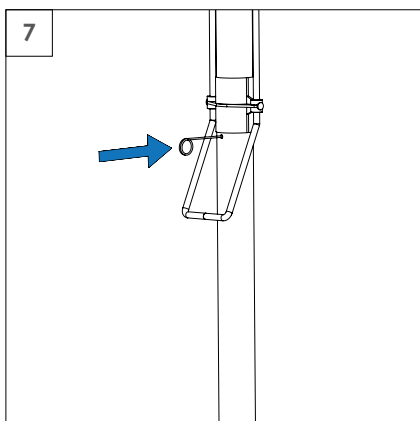
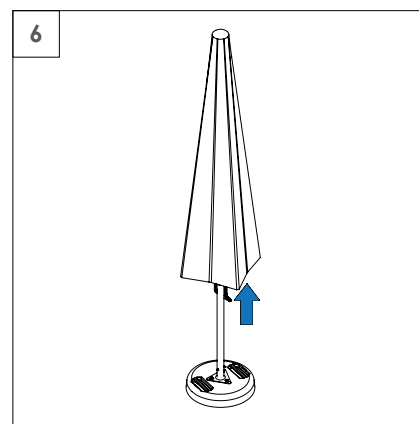
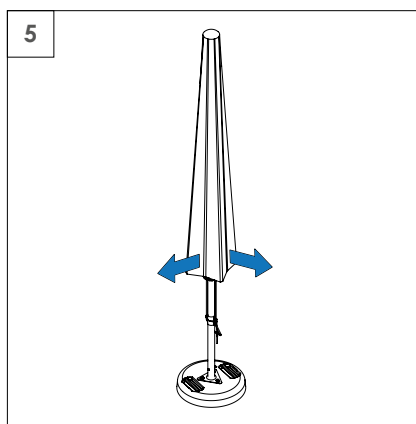
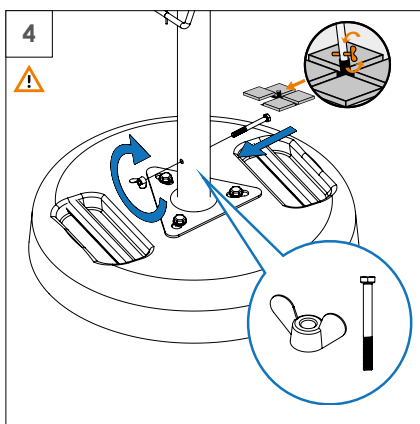
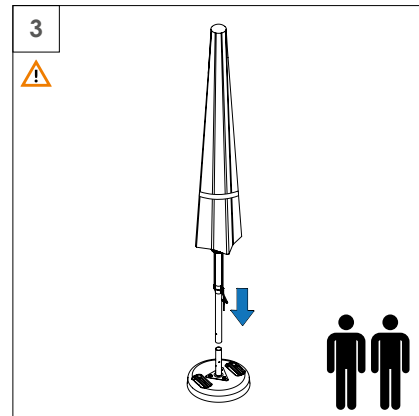
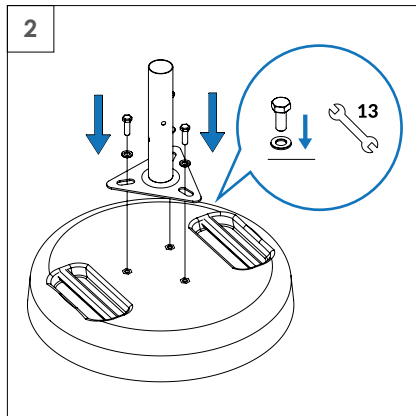
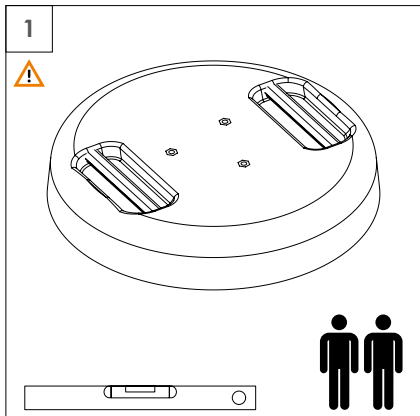

6.3. Mounting of the parasol + Protective cover PD700MR: 4 m / 8

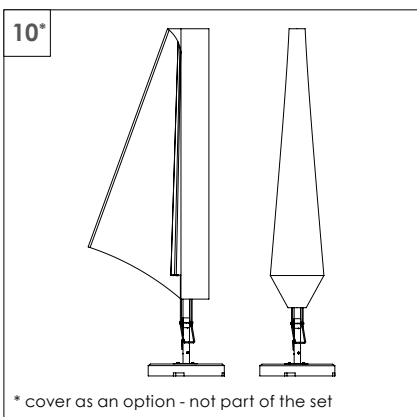
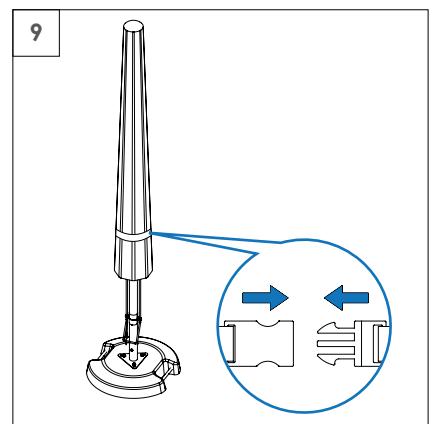
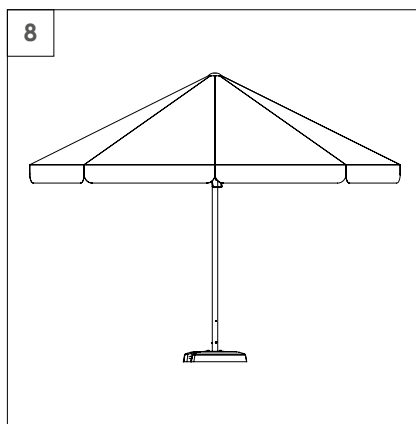
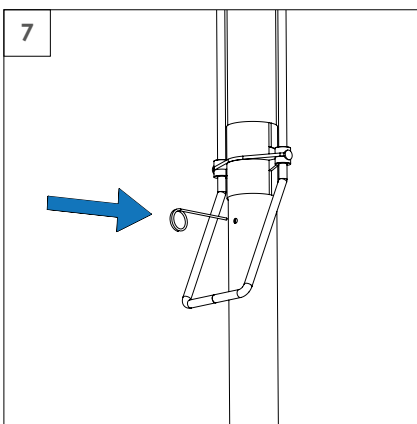
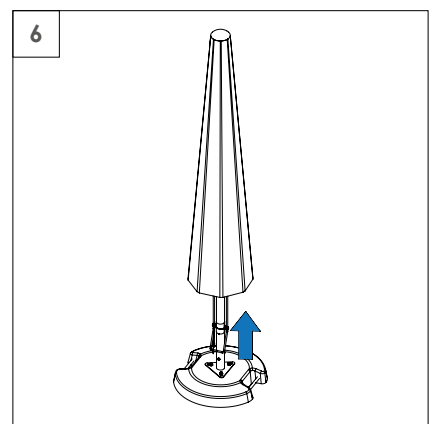
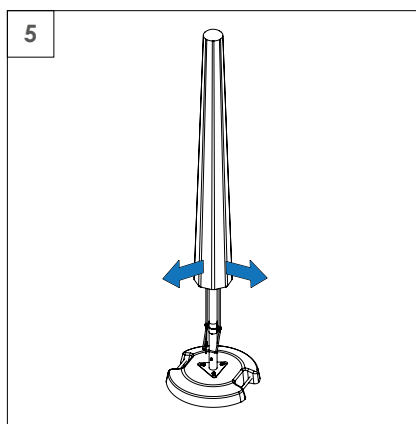
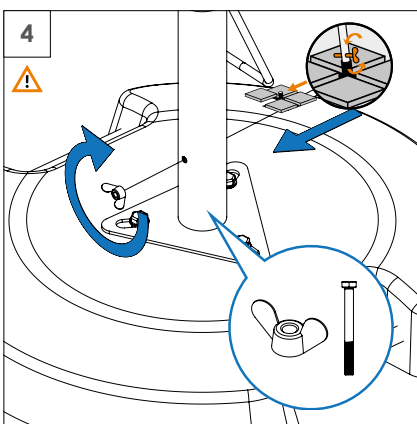
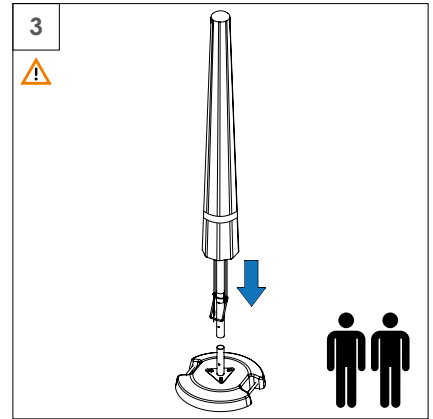
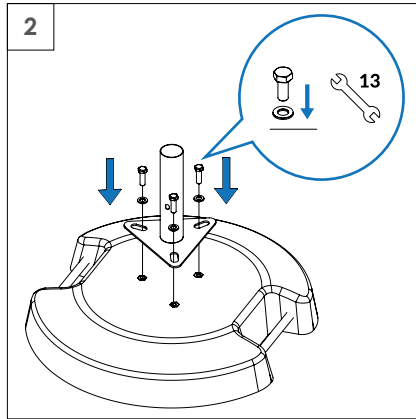
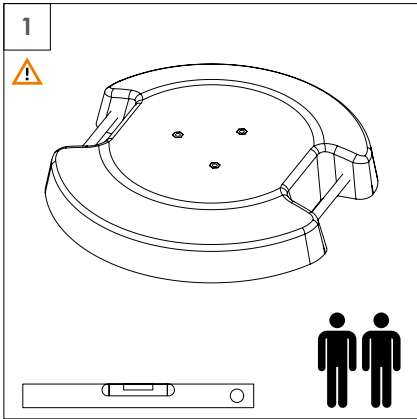

7. Exploitation of the parasol

7.1. Opening the parasol

⚠ Warning: Risk of an accident!

Before opening the parasol make sure that there are no people or objects near it. To unfold the parasol canopy:

Fig. A. Unfasten the safety band and help yourself by extending the arms of the parasol while lifting the up the handle.

Fig. B. Lift the handle until the arm reaches „skip” and the crossbar stops.

Fig. C. Reposition the pin (a type of blocking pin on a string that secures the canopy from sudden closure).

Fig. D. Check the safety catch.

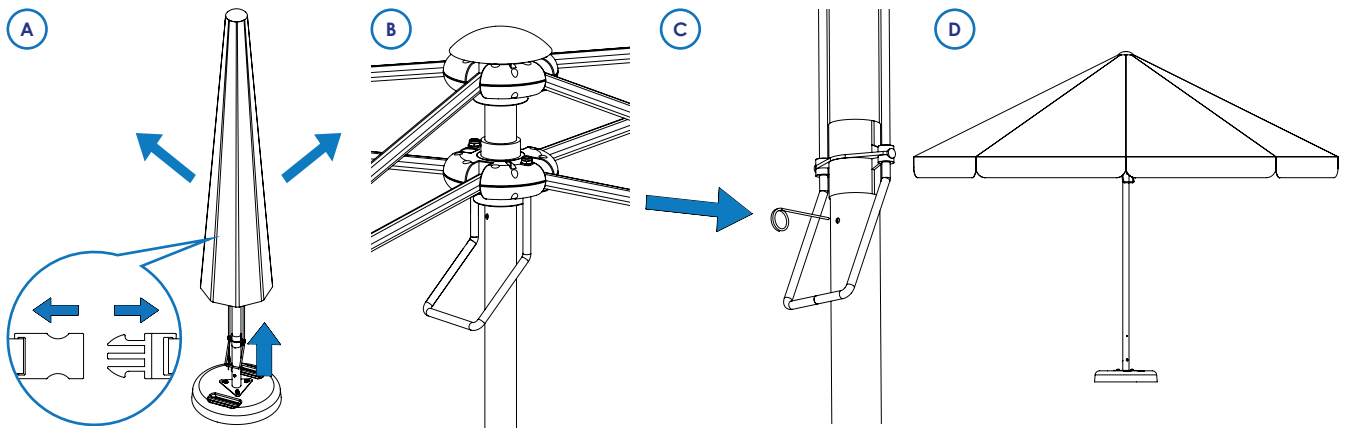

7.2. Closing the parasol

⚠ Attention: Safety hazard

Before closing the parasol, make sure that there are no people or objects near it. To fold the parasol canopy:

Fig. A. Unwind the cord from the cleat (a type of blocking pin on a string that secures the canopy from sudden closure).

Fig. B. Pull the spool out from under the lower crossbar, and then slowly lower the canopy by loosening the cord.

Fig. C. Fasten the safety band.

💡 Tip

In order to avoid staining of the cover, you should only close the parasol in dry weather conditions. We also recommend purchasing a protective cover. If the parasol has been closed while being wet, open it as soon as possible and let it dry. The parasol does not rotate around its axis. Any kind of position change may take place only after folding the parasol. It is advisable to seek the help of a second person.

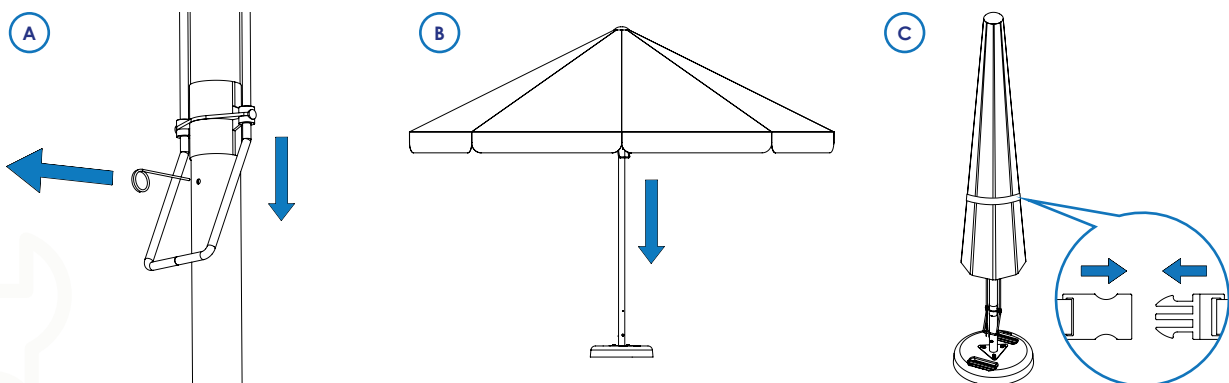

⚠ Attention: Safety hazard

FASTEN THE SAFETY BAND (Fig. C). Failure to fasten the band may cause the parasol to open automatically during a gust of wind, which poses a further risk of health loss, property damage, and even loss of life.

8. Maintenance and care

The customer should carry out a thorough inspection of the parasol using the list below, after the first installation or before storing the parasol. Do not use any sharp tools such as knives or metal scrapers or caustic cleaners to clean the parasol. Do not use water garden hoses or high pressure cleaners when cleaning.

Canopy / Textile:

- Do not chemically clean the canopy / fabric.
- Water wash by hand - lightly squeeze.
- Surface wash - lightly rub heavily soiled areas with a wet sponge. Washing temperature-maximum 40°C.
- Type of washing agent - light washing agents for coloured products, e.g. grey soap.
- Draining and drying - do not twist, dry upright hanging in the open air at 19 - 25 degrees Celsius.
- Do not use organic or chemical solvents and do not chlorinate.
- Keep away from open flames. In case of arson, extinguish with water, powder or snow extinguisher.

Frame construction elements:

- Clean with a damp cloth soaked in soapy water or washing-up liquid. To remove dust, dirt and other contaminants deposited on the structure.
- Before the start of the summer season it is recommended to maintain the mast tube on which the parasol opening mechanism moves. The mast tube should be cleaned with a cloth soaked in benzene (do not use on plastic parts) and then a thin layer of silicone oil should be applied to make the mechanism work easier.

Removing the sheathing:

Necessary tools: phillips screwdriver

STAGES:

- Detach the Velcro fasteners from the main frame arms.
- Remove the pockets securing the sheathing to the frame on the long arms.
- Unscrew the straps securing the sheathing to the frame on the short arms.
- Remove the sheathing.

Putting the sheathing on is carried out in reverse order.

Annual maintenance:

The customer should carry out a thorough inspection of the parasol using the list below, after the first assembly or before storing the parasol for a long time.

Control activities	Check the canopy	Check the handle for unfolding the canopy and the pin	Check the frame for damages
Problem solution	In case of damage replace the sheathing ¹	In case of damage change the string ¹	In case of damage replace the frame ¹
Control activities	Check the plastic stop (point 7.1 Fig. B)	Check the stability of parasol base	Check visually the parasol technical condition
Problem solution	If it is damaged, replace it ¹	If damaged, replace the damaged part ¹	Replace the damaged part

¹ Please contact the manufacturer's service: www.litex.pl

9. Storage

The parasol and all its parts must be stored in a dry, frost-free room.

To avoid stains or dirt, before folding the parasol:

- Clean the base, frame and cover,
- Allow the covering to dry completely,
- If you have bought a protective cover you should put it on and store the parasol in this way. If you don't have a dedicated cover you should protect your parasol with another form of protection such as air permeable fabric,
- Keep out of reach of rodents.

10. Service and parts

If you have any questions about installation or ordering spare parts, please contact your account manager. In the event of a complaint, please register it via the complaint form available at www.litex.pl.

11. Support

You've got doubts? Not everything is understandable?

Contact us:

e-mail: info@litex.pl

12. Diagram of dismantling the parasol

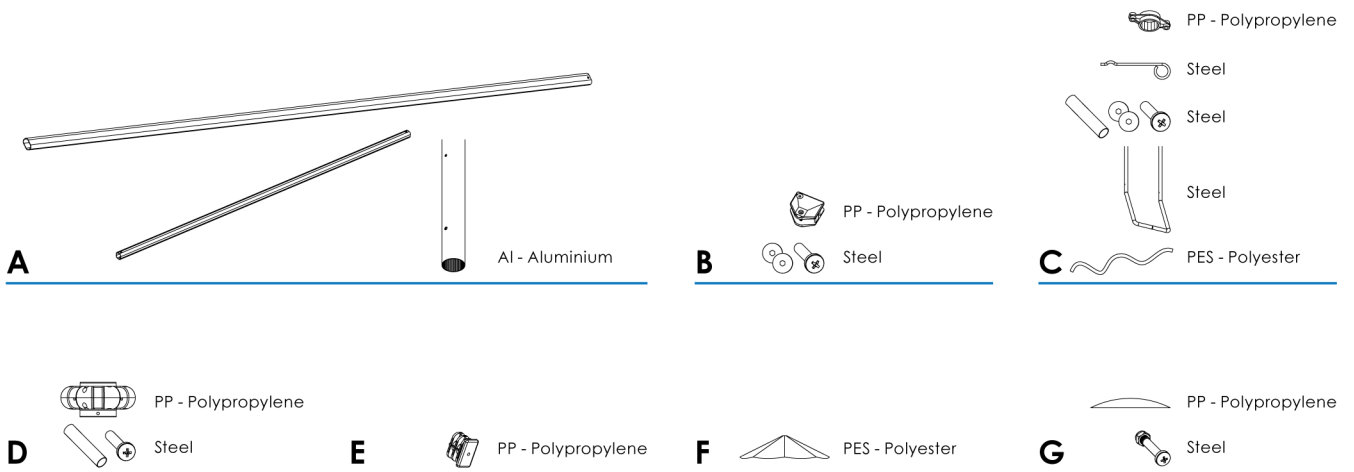
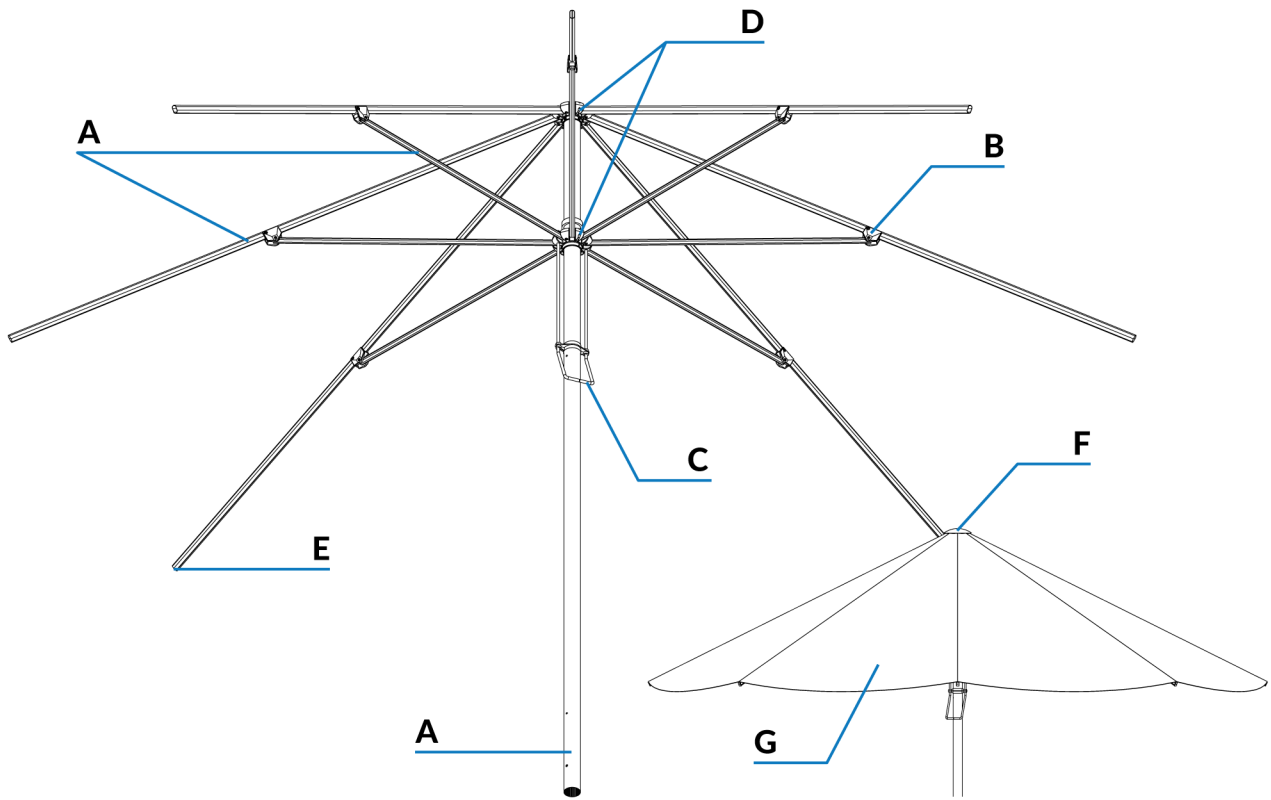

Useful life: until the product retains its useful qualities. Disassembly is performed by the product owner.
 Recycling method for all materials except the covering: material. Recycling method for the cover: fuel. Manual work required.



Litex Promo Sp. z o.o.
Staroprzygodzka 117
63-400 Ostrów Wielkopolski

info@litex.pl
www.litex.pl